

REVISIONS						
LTR	DESCRIPTION	DATE	DRN	CHK	APP'D	ECN NO.
A	INITIAL RELEASE	30-JUN-2016	DR	RS	MB	-

\*ADVANCED\*  
30-JUN-2016

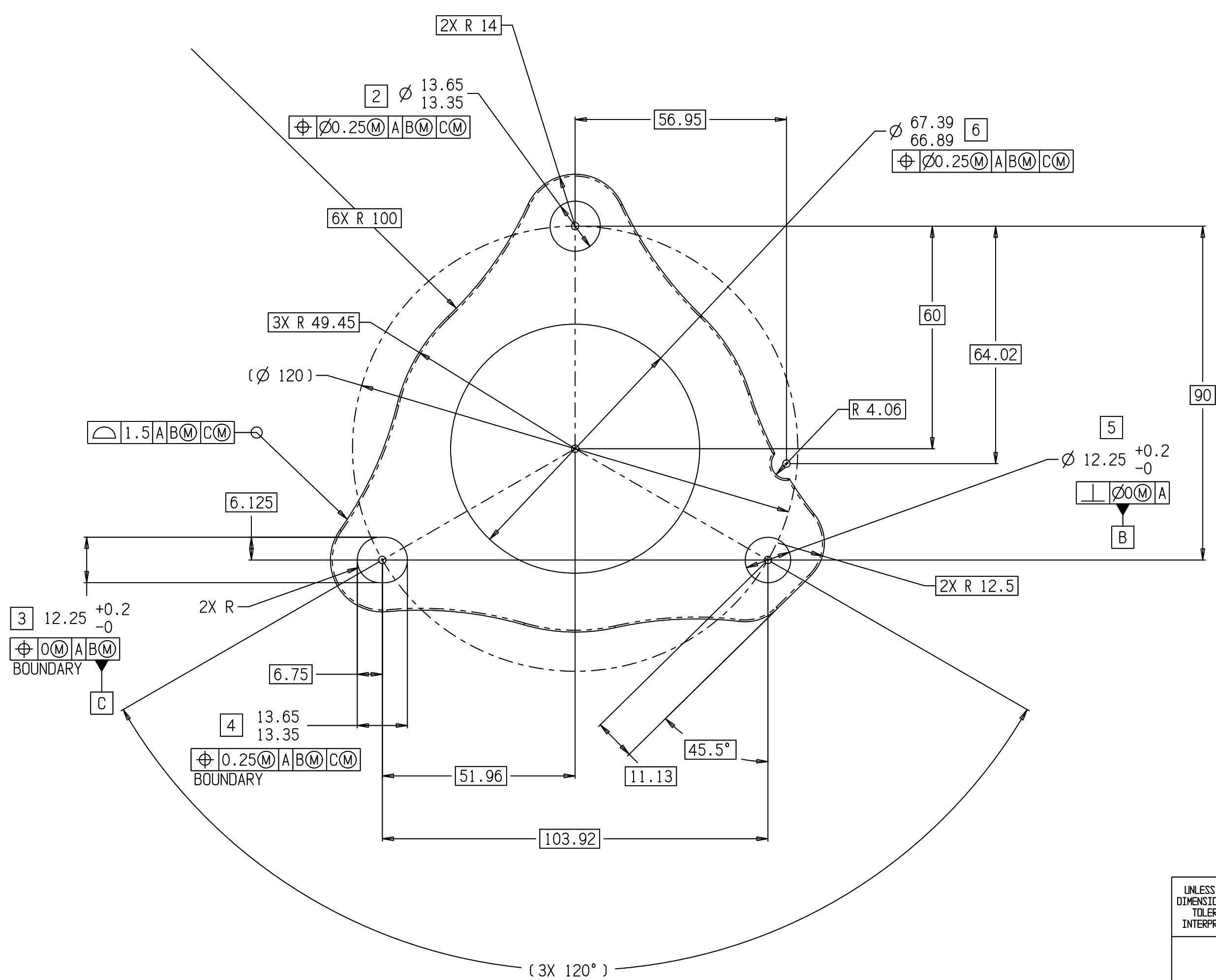
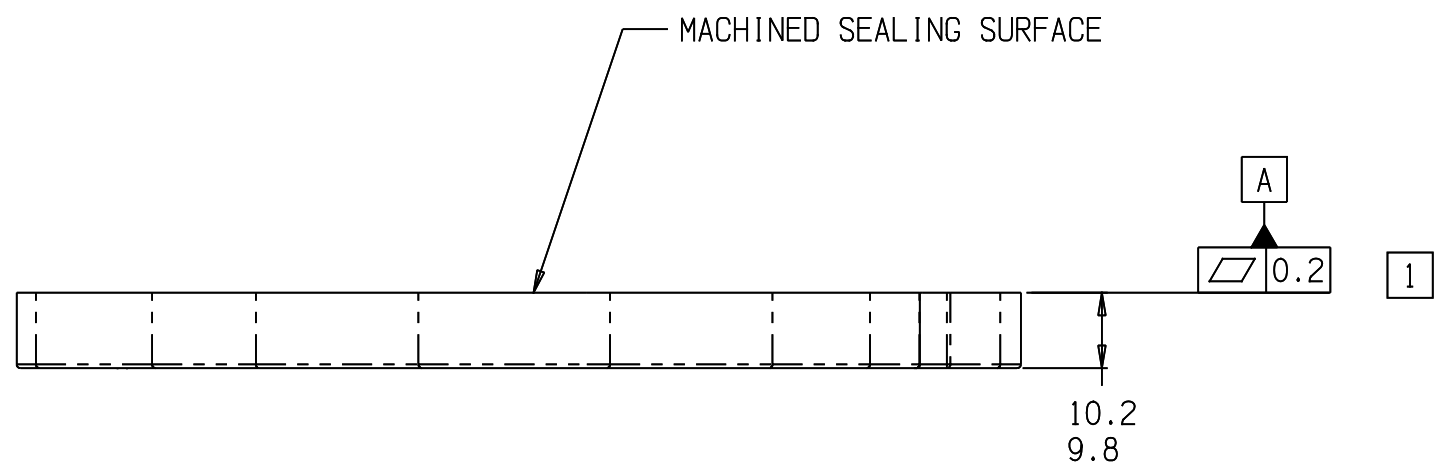

NO POROSITY ALLOWED IN THESE ZONES

UNLESS OTHERWISE SPECIFIED:

CAD MODEL IS MASTER

ALL SURFACES

1.5

SURFACE FINISH SPECIFICATION FOR MACHINED SEALING SURFACES:

Rz = 12 μm MAX  
Rmax = 15 μm MAX  
Wt = 10 μm MAX

OPTIONAL:  
Ra = 2.0 μm MAX  
Rt OR Ry = 15 μm MAX  
Wt = 10 μm MAX

MEASUREMENT CUTOFF = 2.5mm FOR WAVINESS, 0.8mm FOR ROUGHNESS  
MEASURE PERPENDICULAR TO MACHINING MARKS  
BALL SIZE = 5 MICRON  
STYLUS TYPE = SKID-LESS  
FILTER TYPE = GAUSSIAN

REMOVE OIL, LUBRICATION, DEBRIS, BURRS AND  
BREAK ALL SHARP EDGES

CASTINGS SHOULD BE SMOOTH, CLEAN, FREE OF POROSITY,  
CRACKS, INCLUSIONS, FINS, CARBIDES, AND RUST

CASTING MUST NOT SMOKE ON START UP AT ASSEMBLY PLANTS

MATERIAL: CH10 (309S) PER ASTM A351 EXCEPT NO HEAT TREATMENT,  
TS 350 MPa MIN, YS 125 MPa MIN, ELONGATION 25% MIN.

NET WEIGHT: 0.510 KG (1.124 LBS)

UNLESS OTHERWISE SPECIFIED ALL DIMENSIONS ARE IN MILLIMETERS AND TOLERANCES ARE GIVEN BELOW, INTERPRET PER ASME Y14.5 - 2009	THIS DRAWING AND THE INFORMATION CONTAINED HEREON IS THE PROPERTY OF FLEXIBLE METAL, INC. IT IS LOANED FOR THE EXPRESS PURPOSE OF QUOTATION AND/OR FABRICATION AND MUST BE RETURNED UPON DEMAND. THE INFORMATION CONTAINED HEREON IS TO BE KEPT STRICTLY CONFIDENTIAL.		7495 East, M-36 Hamburg, MI 48139 810-231-1300	
	DO NOT SCALE DRAWING		TITLE: FLANGE, 3-BOLT	
	METRIC SCALE: 1.00			
	DRAWN BY: D. REYNOLDS	DATE: 30-JUN-2016		
	APP'D BY: M. BLACKIE	DATE: 30-JUN-2016		
REFERENCE:	CODE IDENT	SIZE	DRAWING NUMBER:	REV
	-	C	FLG-0016-309-5018	A